

Panel Installation

All Sub-Zero units easily accommodate front, grille and side panels as long as you follow the points listed earlier in the Integrating Cabinetry section of this guide. Installation is easy following these steps.

Front Panel Installation

If a metal or other thin material is used, a filler must be inserted behind your panel to ensure a proper fit. All frames are designed to accept up to $\frac{1}{4}$ " material. Thicker pieces must be routed to the $\frac{1}{4}$ " perimeter dimension. There is a 50 lb. weight limit for each door panel.

Models 501R, 501F, 511, 532, 550 and 561

Remove the door handle by first removing the trim molding as shown in Figure 17. The molding easily comes off by using a piece of tape to pull it away from the handle. This removal will expose the handle screws.

With a standard Phillips screwdriver, remove door handle on freezer and refrigerator door. The models 511 and 550 freezer door handle is on the top of the door and removed in the same manner.

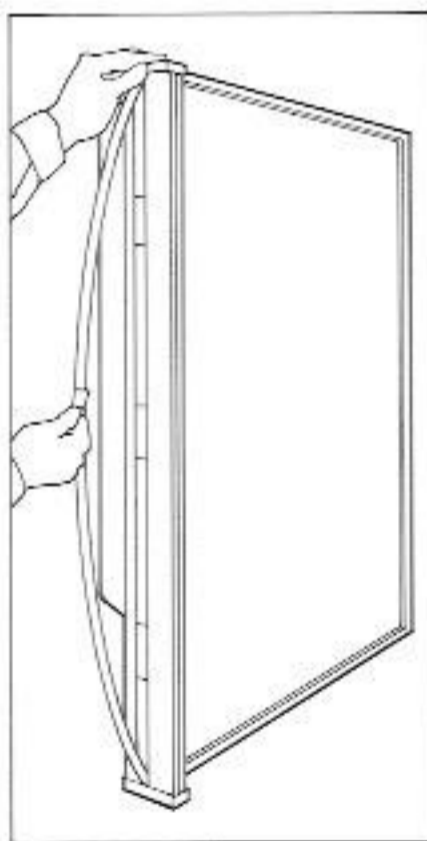

Figure 17

Slide the appropriate panel into the frame as illustrated in Figure 18.

With the panel in position, replace handle, screws and trim molding. The molding is replaced by bowing the piece gently in the middle and inserting the top and bottom edges into the handle channel first and then release the middle.



Figure 18

Model 590

Remove the trim molding in an identical manner as illustrated in Figure 17.

Once the molding is removed you can easily remove the door screws on both the refrigerator and freezer doors by using a standard Phillips screwdriver.

Remove the handle trim panels by sliding them out of the door(s) as shown in Figure 19. Complementary colored handle trim panels and glasswells are available through your product distributor.

Next, remove the ice and water glasswell by removing the mounting screw. Then slide the glasswell up and pull out as shown in Figure 19.

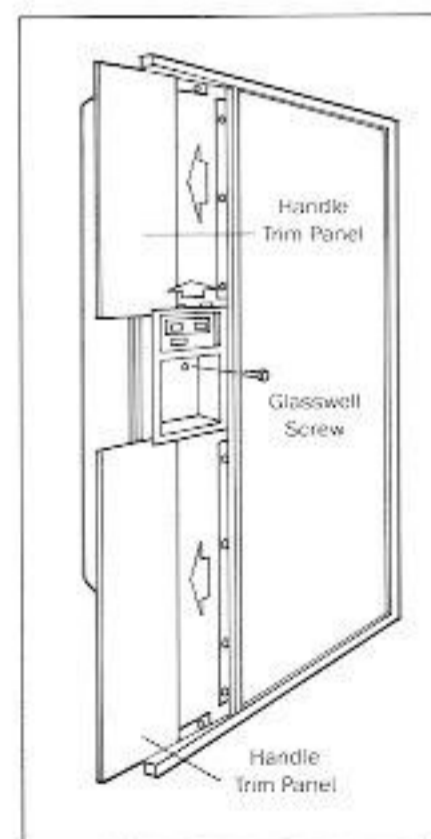

Figure 19

Remove the top and bottom trim fillers held on by the mounting screws. See Figure 20.

In similar fashion remove the screws holding the vertical trim strip. See Figure 20.

Install the door panels by sliding them into the frame on the door and reverse the earlier steps to reassemble.

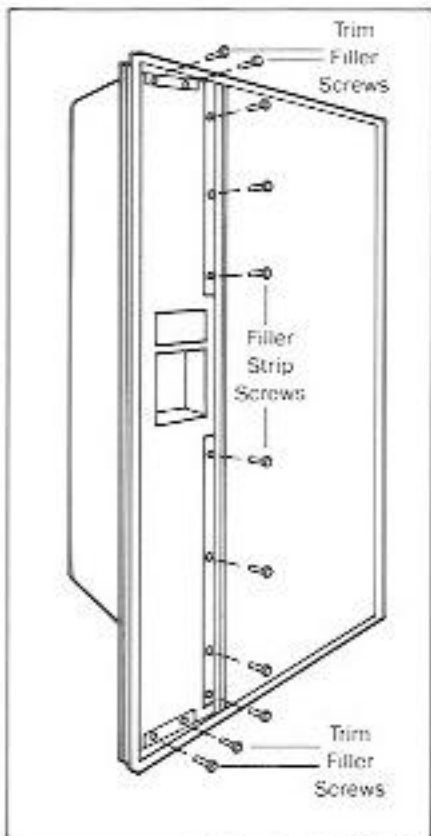

Figure 20

EA Grille Panel – Model 590

Remove the inner grille panel assembly (refer to Figure 9 on page 14) and remove the top two corner screws and pull away the top frame. See Figure 28.

Lay the remaining panel assembly on a flat surface and insert the panel insert into position in the grille frame as shown in Figure 28.

Reattach the top frame and install the inner grille panel assembly back onto the unit. See Figure 9 on page 14.

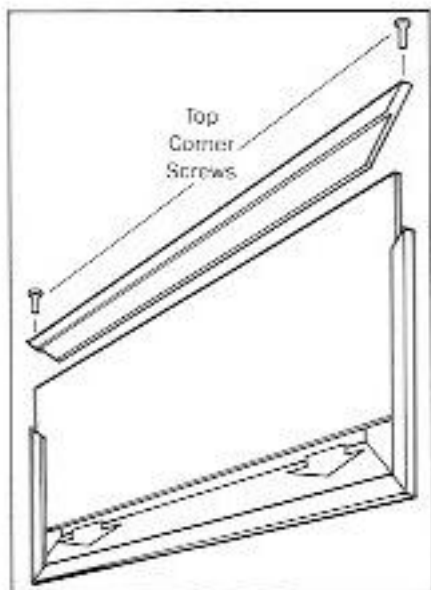

Figure 28

Features and Options

Sub-Zero's integrated design, beauty and quality is evident in all of these features that are standard on Sub-Zero's seven full-size units.

- **Built-in Design.** All Sub-Zeros are only 24" deep. They accept decorative door and side panels (50 lb. weight limit per door panel), to match virtually any cabinetry. The perimeter thickness cannot exceed 1/4". See pages 12 and 13 for details.

- **Colored Panels.** Optional steel door and side panels are available from our factory in three colors: almond, stainless steel and white. (Model 590 offers your choice of seven complementary colored glasswells and ten optional color handle inset trim panels at no cost. The standard colored glasswell is pewter gray and handle inset trim panel is pin-striped pewter gray.)

- **Satin Trim.** Door screws are hidden on these units so you have a clean look.

- **Door Handles.** All units have our low-profile door handles as a standard feature. A D-style handle is an option on Models 501R, 501F, 511 and 550. An extended full-length handle is also offered as an option on all models. Refer to Figure A, Page 10A for panel sizing information.

- **Grilles.** Sub-Zero's 11" louvered grille is standard on all models with the exception of the Model 590. An optional easy-access panel grille that accepts decorative panel inserts is also available. In either instance, you can order them in one inch increments from 10" to 15". (Model 590 has the EA panel grille standard.)

- **Toe Plate.** Adjustable, solid toe plate meets the standards of the American Institute of Architects. Inset area is 4" high by 3" deep.

- **Adjustable Shelves.** Cantilever glass shelves in the refrigerator, wire shelves in the freezer and all of the door shelves are adjustable.

- **Crispers.** Each crisper has its own humidity control and moves easily on our roller track system.

- **Ice Maker.** Each Sub-Zero freezer offers an automatic ice maker providing crescent-shaped ice.

- **Utility Basket.** Smaller items are stored in the refrigerator's adjustable utility basket.

- **Dairy & Egg Modules.** Two dairy compartments have full magnetic seal to maintain freshness. A portable egg tray offers handy storage and is removable.

- **Diffused Lighting.** Sub-Zero's overhead lighting floods both the refrigerator and freezer compartments with even light.

- **Dual Compressors.** Two compressors in all our combination refrigerator/freezer units deliver precise, and independent temperature in the section it controls.

- **Automatic Defrost.** Sub-Zero refrigerator and freezer units have an automatic defrost system.

- **Front Venting.** All Sub-Zero units are front vented so you can plan for a truly built-in refrigerator.

- **Door Swing.** You can choose left or right door swing on our single door units as well as our over-and-under models. This option must be ordered when requesting the unit. You cannot reverse the door in the field.

- **Magnetic Door Gasket.** Our positive sealing gasket ensures a tight closing door.

- **Roller Base.** Patented roller base assembly allows for easy installation.

- **Door Stop Kit.** For installation where the door swing must be limited to 90 degrees, an optional Door Stop Kit is available. (Normal door swing is 130 degrees with the exception of the 550 and 511.)

Grille Panels

The Sub-Zero 11" louvered grille is standard on all units with the exception of the Model 590. An easy-access (EA) panel grille is available as an option for all models and easily accepts decorative panels. The Model 590 has this 11" EA panel grille as a standard feature.

As with the standard grille, the EA panel grille can be ordered in one inch increments from 10 to 15".

The following sizes should be used when ordering decorative inserts for the EA panel grille. There is a 15 pound weight limit on these inserts.

Grille Size	Panel Size
10 x 30	8 $\frac{1}{16}$ " x 28 $\frac{3}{16}$ "
11 x 30	9 $\frac{1}{16}$ " x 28 $\frac{3}{16}$ "
12 x 30	10 $\frac{1}{16}$ " x 28 $\frac{3}{16}$ "
13 x 30	11 $\frac{1}{16}$ " x 28 $\frac{3}{16}$ "
14 x 30	12 $\frac{1}{16}$ " x 28 $\frac{3}{16}$ "
15 x 30	13 $\frac{1}{16}$ " x 28 $\frac{3}{16}$ "
10 x 36	8 $\frac{1}{16}$ " x 34 $\frac{3}{16}$ "
11 x 36	9 $\frac{1}{16}$ " x 34 $\frac{3}{16}$ "
12 x 36	10 $\frac{1}{16}$ " x 34 $\frac{3}{16}$ "
13 x 36	11 $\frac{1}{16}$ " x 34 $\frac{3}{16}$ "
14 x 36	12 $\frac{1}{16}$ " x 34 $\frac{3}{16}$ "
15 x 36	13 $\frac{1}{16}$ " x 34 $\frac{3}{16}$ "
10 x 48	8 $\frac{1}{16}$ " x 46 $\frac{3}{16}$ "
11 x 48	9 $\frac{1}{16}$ " x 46 $\frac{3}{16}$ "
12 x 48	10 $\frac{1}{16}$ " x 46 $\frac{3}{16}$ "
13 x 48	11 $\frac{1}{16}$ " x 46 $\frac{3}{16}$ "
14 x 48	12 $\frac{1}{16}$ " x 46 $\frac{3}{16}$ "
15 x 48	13 $\frac{1}{16}$ " x 46 $\frac{3}{16}$ "

Any other custom grille must meet required airflow requirements and you should contact Sub-Zero before installing one.

Hinge Adjustment

If the doors are out of adjustment, the top or bottom hinge may be adjusted by removing and discarding the two small shipping screws. See Figure 29. The top door hinges can be adjusted left to right and in or out by loosening the three allen head screws. The bottom door hinge is equipped with two adjustment allen head screws. See Figure 30.

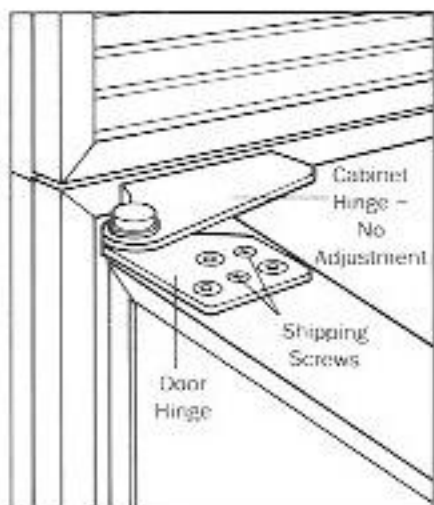

Figure 29

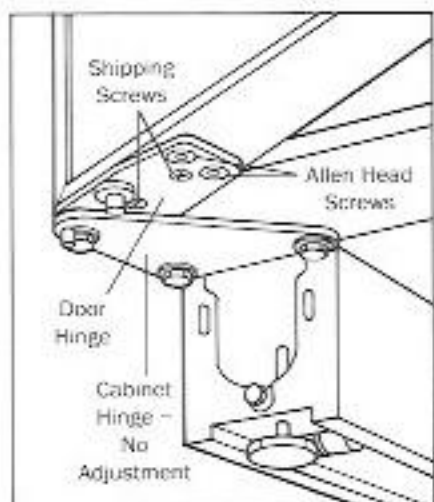

Figure 30

Models 511, 532, 550 and 561

Remove center grille screw and cut the red nylon shipping strap. (NOTE: This screw must be removed before grille is tilted or damage can occur.) Tilt the grille forward and release the spring(s) from behind grille. See Figure 7.

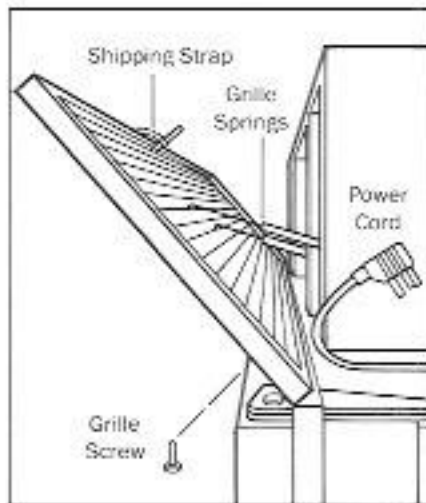

Figure 7

Models 501R and 501F

To remove the 501 grille, remove two (black) screws located in the lowest louver in the grille. Tilt the bottom of the grille out and away, it will release from the top of the grille. There is no grille spring on the 501 units. See Figure 8.

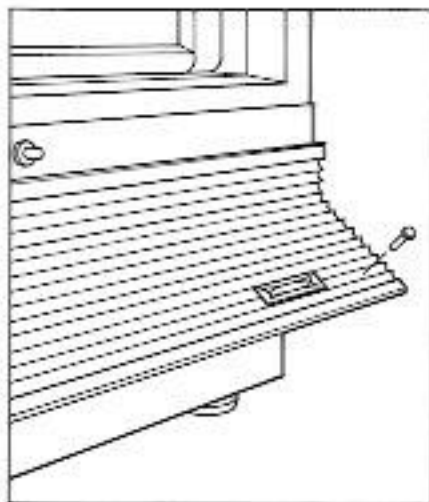

Figure 8

Model 590

To remove Model 590 grille assembly, the inner grille panels assembly must first be removed. Lift up (1), then pull out at the bottom (2), then pull top section down and out of the top key slot (3) as in Figure 9. Next, remove the five mounting screws that hold the outer grille panel assembly to the top compartment. See Figure 10.

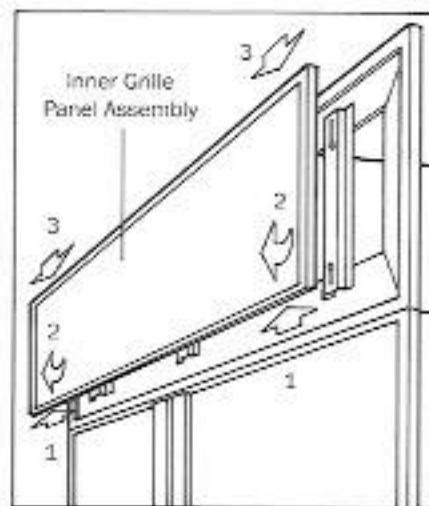

Figure 9

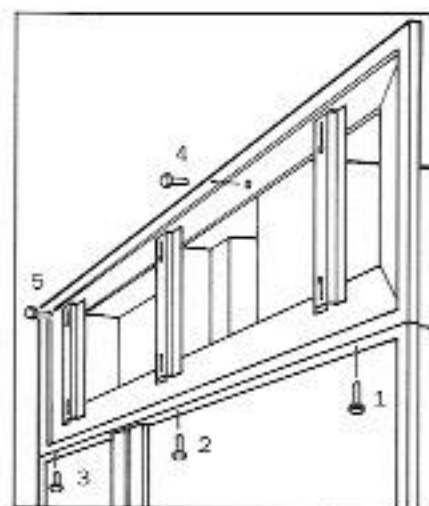

Figure 10

Blocking

⚠ WARNING

To help prevent the unit from tipping forward and provide a stable installation, the unit must be secured in place with a solid soffit or wood block.

If there is a solid soffit above the unit with clearance between the unit and the soffit of one inch or less, as illustrated in Figure 11, you do not need to block the unit. If this is not the case, **you must block the unit.**

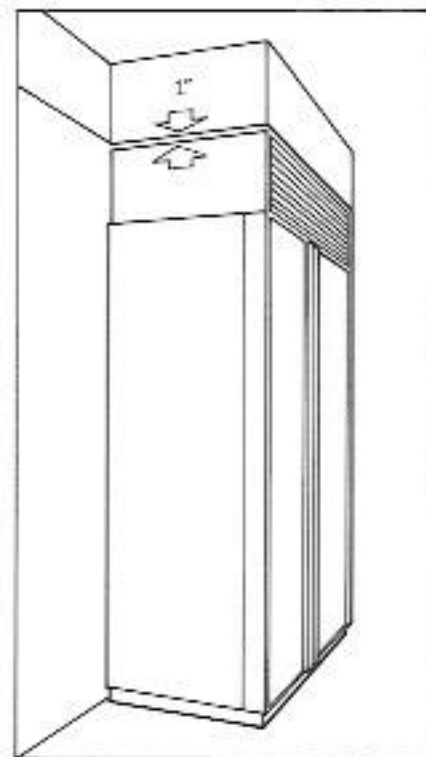

Figure 11

To block the unit, using the wood block and hardware provided, follow these steps:

- Locate and mark two wall studs against the wall where the refrigerator is to be located.
- Locate the proper height to clear the unit. The space along the top of the Sub-Zero between the unit and the bottom of the wood block **must not be greater** than $\frac{1}{4}$ inch. See Figure 12.
- Position the wood block over the unit and secure it using the screws and "L" brackets provided. Make sure screws extend a minimum of $\frac{1}{8}$ of an inch into each of the two wall studs. The wood block must extend a minimum of three inches over the unit. See Figure 12.
- Using the front and rear levelers, the unit must be raised until it contacts the wood block. See Figure 15.

⚠ WARNING

To reduce possibility of cabinet tipping forward, front levelers must be in contact with floor. See Figure 15.

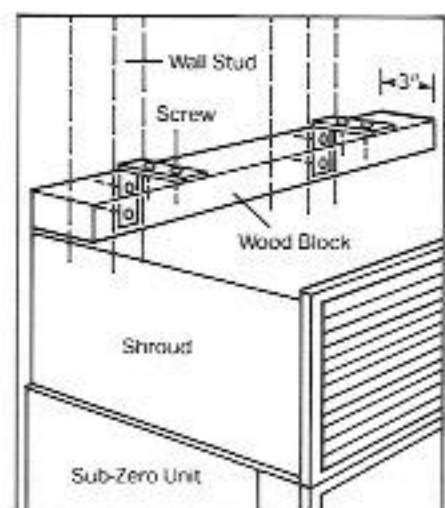

Figure 12

Installing

⚠WARNING

Shut off the power to the wall outlet.

⚠CAUTION

Protect any finished flooring before moving the unit in place. All full size Sub-Zero models are equipped with rollers, so you can easily move the unit into place.

If for any reason, the unit has been laid on its back or side, you must allow the unit to stand upright for a minimum of 24 hours before connecting power.

⚠CAUTION

Plug the unit into 15 amp grounded outlet and roll the unit into desired position. Now you have to connect the ice maker water line.

Cut the red nylon shipping strap holding the garden hose fitting, compression nut and sleeve to the toe plate bracket. Connect the $\frac{1}{4}$ " compression nut and sleeve on the copper tubing to the hose fitting before attaching the fitting to the solenoid valve. Purge the water line before the final hookup to the valve. See Figure 13 and for Model 590 see figure 14.

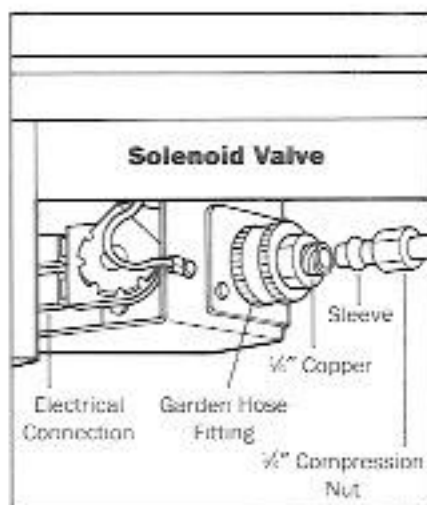

Figure 13

Turn on water supply, check all fittings for leaks and make certain the electrical harness is attached to the solenoid valve. *(NOTE: The ice maker will not immediately fill with water when supplied to the valve. Allow 24 hours for proper ice production.)*

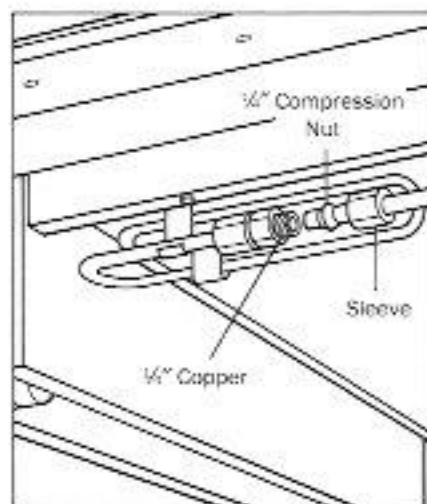

Figure 14

Leveling

With the unit positioned properly you should level the unit by turning the front leveling legs counterclockwise to raise or clockwise to lower. The rear levelers (rollers) are adjusted from the front of the base by turning the $\frac{5}{16}$ " hex bolt clockwise to raise and counterclockwise to lower the cabinet. See Figure 15.

⚠WARNING

To reduce the possibility of the cabinet tipping forward, the front levelers must be in contact with the floor.

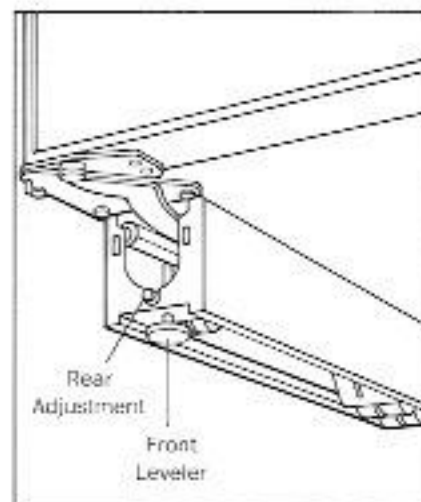

Figure 15

For a finished look to the Sub-Zero install the toe plate as illustrated in Figure 16. However, before completing this step check to ensure the drain pan is positioned properly.

⚠CAUTION

In all cases the toe plate must be removable for servicing so any flooring or molding must allow for this removal. Refer to the label mounted on the kickplate support for height clearance.

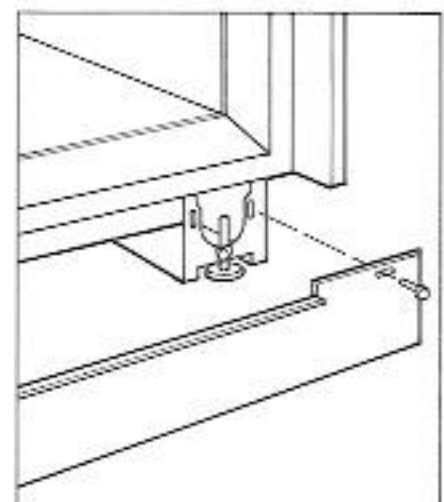

Figure 16

Installation Instructions

Moving Unit

The installation of a Sub-Zero is an easy task if you have done the necessary preparation. Before bringing the unit into a house, it should be uncrated outside. Remove the box and wood base and discard this material. Do not discard wood block and hardware to be used for blocking your unit.

In addition retract front leveler legs to ensure easier movement of the unit for installation.

▲WARNING

To reduce the possibility of the unit tipping forward, you must reposition the front levelers to make contact with the floor. You will have to extend these legs when the unit is finally positioned.

You should remove the grille for easier transportation through doorways and later access to the power cord.

Planning Information

Area Requirements

Before moving ahead with any planning you should be aware of the basic requirements for the installation of a built-in Sub-Zero. The drawings in Figures 1 and 2 illustrate the finished rough in dimensions, electrical and plumbing locations and minimum door clearance for all units.

MODEL	Finished Rough Opening Dimensions		Minimum Door Clearance Required at 90°	Minimum Height Required (with levelers in)	Recommended Electrical Outlet Location		Water Supply Location
	A	B			C	D	
501F	35½"	72¾"	36¾"	72¾"	3"	6"	—
501R	35½"	72¾"	36¾"	72¾"	3"	6"	—
511	29½"	83¾"	30 ¼"	82¾"	75½"	—	—
532	47½"	83¾"	29¼"	82¾"	75½"	—	—
550	35½"	83¾"	36¾"	82¾"	75½"	—	—
561	35½"	83¾"	20¾"	82¾"	75½"	—	—
590	47½"	83¾"	29¼"	82¾"	75½"	—	—
506	18"	34½"	11¾"	—	2½"	2½"	11"
801	35½"	34½"	18½"	—	½"	6"	18"
249R	24"	34½"	25¾"	—	10½"	8½"	—
249RP	24"	34½"	25¾"	—	10½"	8½"	—
249FF	24"	34½"	25¾"	—	10½"	2½"	18"
245	24"	34½"	25 ¼"	—	1"	2"	12"

(FOOTNOTE: When using frameless cabinets, you must add space to the finished rough opening to allow for side mainframe overlap to ensure cabinet and Sub-Zero doors open properly. This space will fluctuate depending on the installation and overall visual appearance you are trying to achieve.)

(FOOTNOTE: When installing cabinets with six inch bases, add two inches to the minimum height detailed above, if you want to make the base of the Sub-Zero even with the cabinets.)

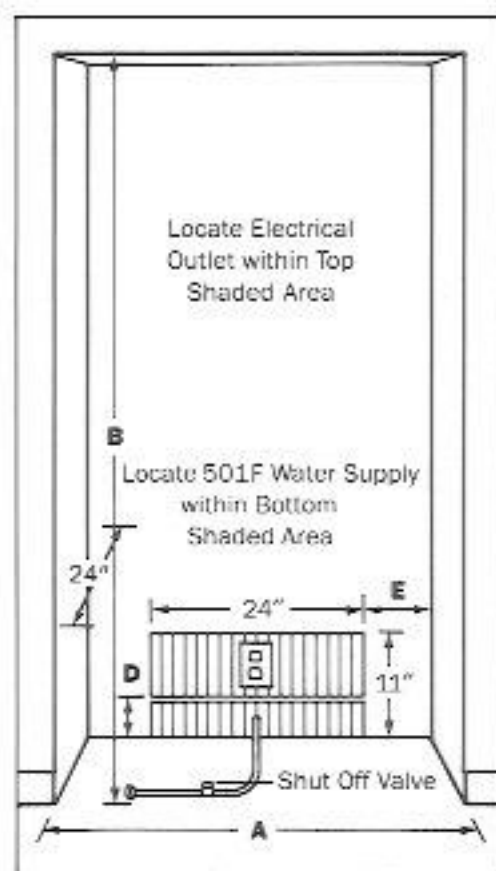

Models 501F and 501R

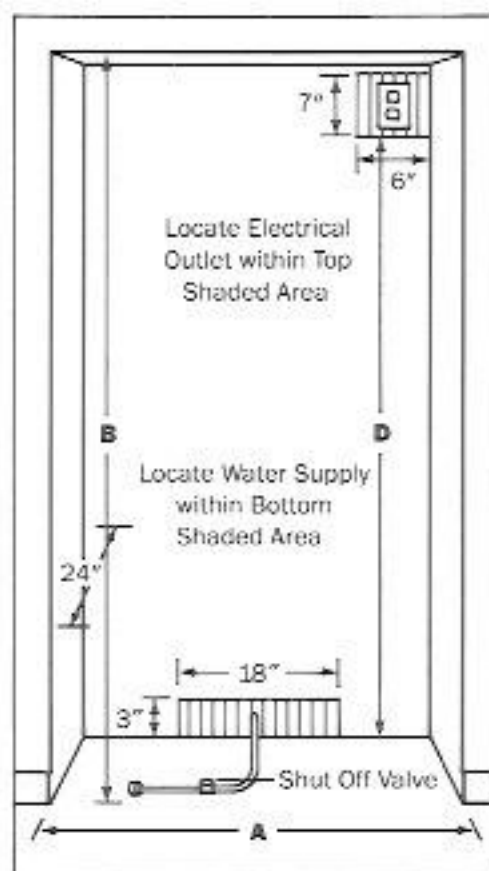

Models 511, 532, 550, 561 and 590

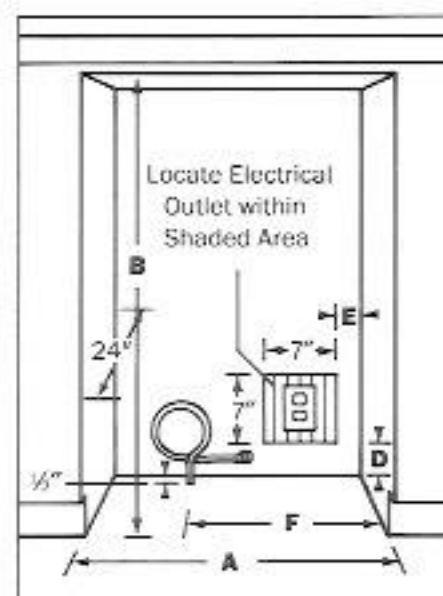

Models 506, 801, 249R, 249RP, 249FF and 245

Figure 1

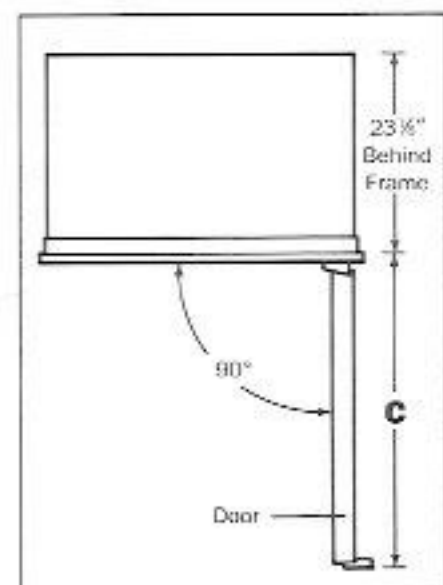

Figure 2

Electrical

A 115 volt, 60 Hz, 15 amp fused electrical supply is required. It is recommended a separate circuit, serving only this appliance, be provided.

All Sub-Zero units are equipped with a power supply cord with a 3-prong grounding plug and it must be plugged into a mating 3-prong grounding type wall receptacle. Follow the National Electrical Code and local codes and ordinances when installing the receptacle. Refer to figures and chart on page 10 for exact specifications.

Plumbing

For units with an automatic ice maker, rough in the water supply line. Connect a 1/4" OD copper line to the house supply being sure to use an easily accessible shut off valve between the supply and the refrigerator.

Do not use "self-piercing" valves. A saddle valve kit (part #4-20-088-0) is available from your distributor/dealer. A line filter is required when water conditions have a high sediment content.

The water line should be routed up through the floor within 1/2" from the back wall no higher than 3" off the floor. If you have to come through the wall, make sure the water line is no more than 3" from the floor.

Regardless of the routing, allow two to three feet of excess copper tubing to remain outside the wall or floor for easy connection to the unit. Refer to figures and chart on page 10 for exact specifications.

Door Clearance

It is important to keep in mind that all installations must allow for the units to open a minimum of 90 degrees or you will have problems removing crispers and drawers. With the door opening at 90 degrees, you may have to move drawers or crispers slightly to clear the door interior. Refer to minimum door clearance on page 10.

- For corner installations, you must allow for a minimum two inch filler to assure door opens to 90 degrees. Where raised panels are used, you may want to consider a wider filler.

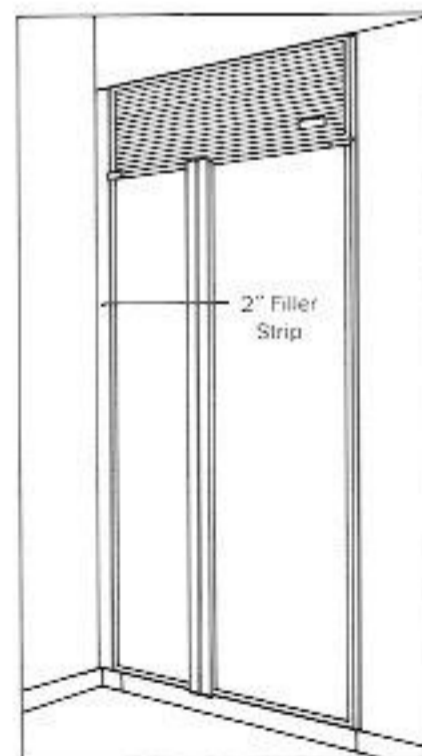
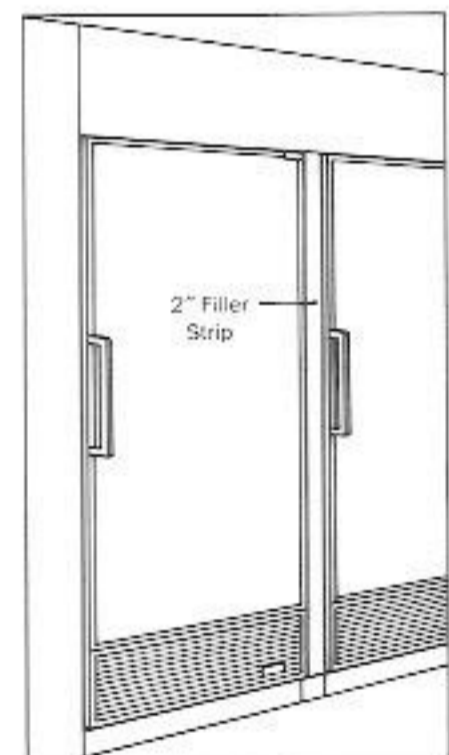

Figure 3

- When units are installed side by side a filler strip is recommended. Depending on the configuration and panels used, this filler strip will vary.
- Keep in mind the filler strip width should be added to your finished rough in dimension. In any side by side installation, an additional half inch should be added to your combined numbers.

(FOOTNOTE: Refer to full scale drawings on center pages 10A and 10B, Figures A, B and C for specifics on door openings and filler size alternatives.)



(Optional D-Style Handle shown) Figure 4

Side Panels

If side panels are being utilized, check with your installer for installation suggestions or consider these options.

In any of these installation alternatives, you must drill three holes equal distance apart in the vertical section of the aluminum frame and install #6 x $\frac{3}{8}$ " pan head screws to hold the panels in place. See Figure 22.

Anchor the back portion of the side panel with decorative screws or nails. Refer to Figures 23-27.

We do not recommend the use of adhesives.

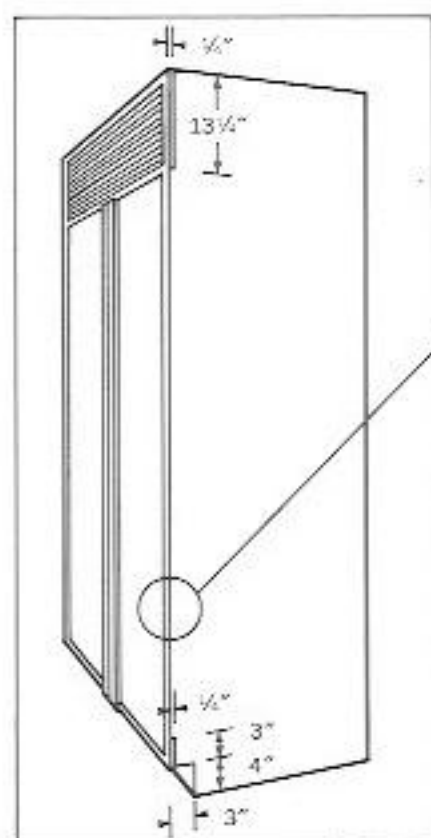

Figure 21

The dimensions supplied are for a typical wood side panel. If $\frac{3}{4}$ " panel or less is used and inserted into the return channel on the extrusion then a 24 $\frac{1}{4}$ " size is necessary. The sheet must also be notched as shown in Figure 21.

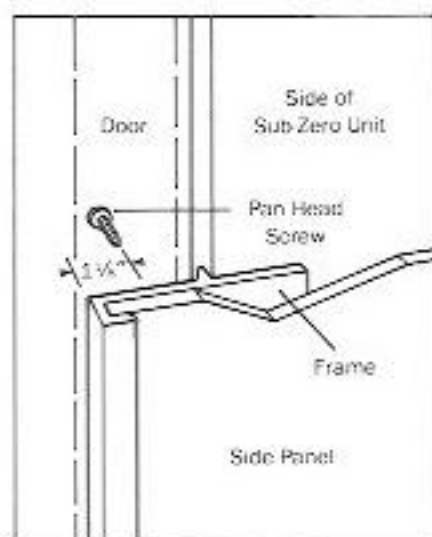

Figure 22

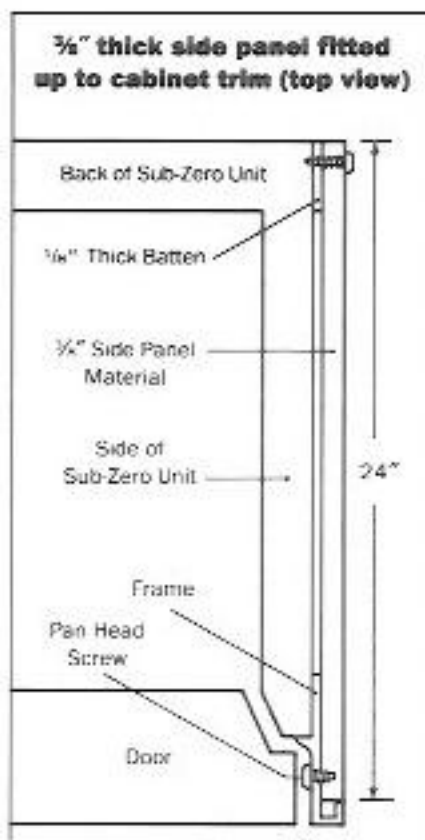

Figure 23

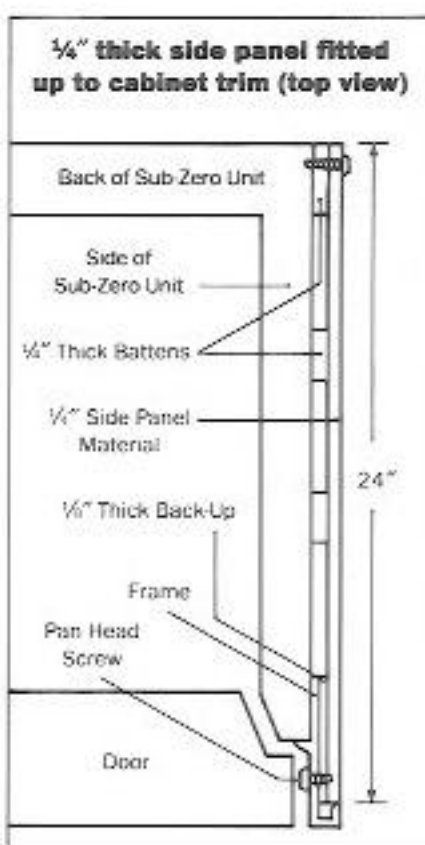

Figure 24

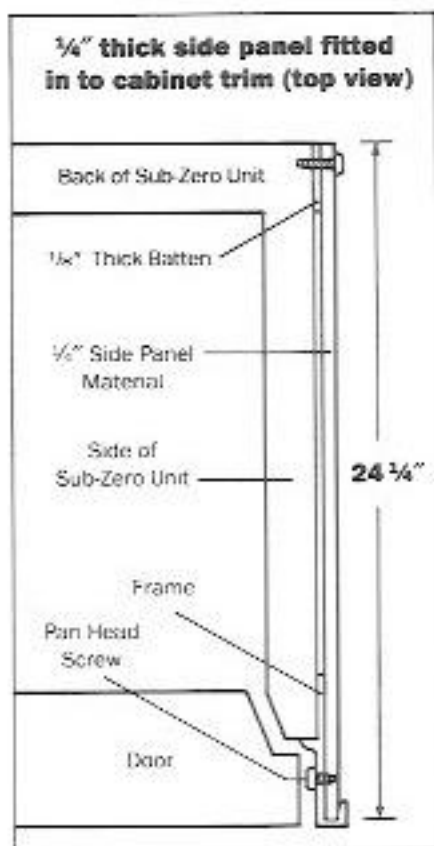

Figure 25

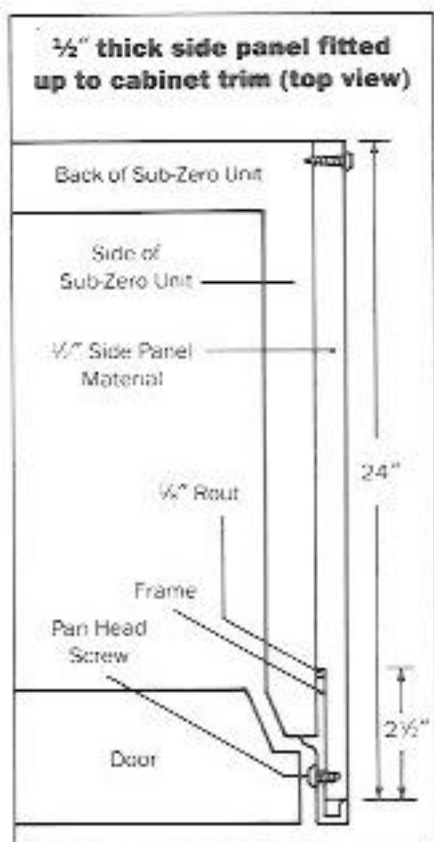

Figure 26

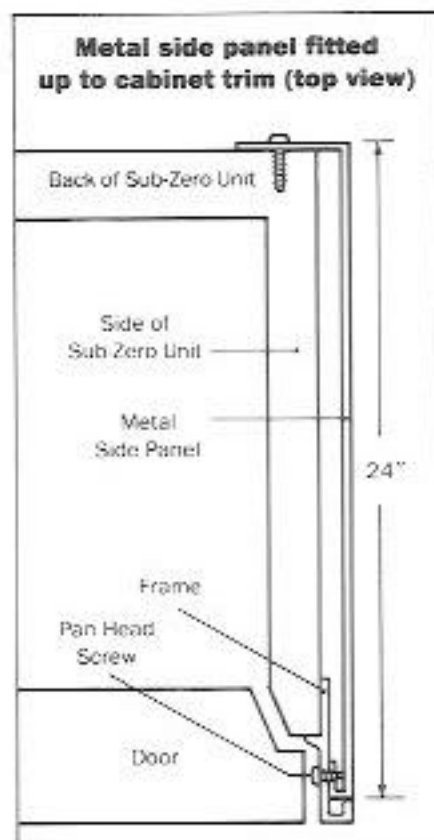

Figure 27

Integrating Cabinetry

Door Panels

The beauty of a built-in Sub-Zero is its ability to easily accept decorative panels on the front, side or grille area. Optional steel door panels are available from Sub-Zero in three colors – almond, stainless steel and white. If, however, you choose to install different panels to complement your kitchen cabinetry, follow these sizes. In some instances raised panels may require a handle recess. On the units where this may be necessary, standard specifications are provided in the drawings and columns D, E and F. (**Weight limit per door panel:** 50 lbs. on full size units; 20 lbs. on under-counter models.)

MODEL	A (width)	B (width)	C (height)	D	E	F
532	17 ¹ / ₁₆ "	27 ¹ / ₁₆ "	67 ¹ / ₁₆ "	—	38 ³ / ₃₂ "	—
561	14 ³ / ₁₆ "	19 ³ / ₁₆ "	67 ¹ / ₁₆ "	—	38 ³ / ₃₂ "	—
511	28 ¹ / ₈ "	—	48 ¹ / ₁₆ "	18 ³ / ₁₆ "	24 ¹ / ₃₂ "	14 ¹ / ₁₆ "
550	34 ¹ / ₁₆ "	—	48 ¹ / ₁₆ "	18 ³ / ₁₆ "	24 ¹ / ₃₂ "	17 ¹ / ₁₆ "
501F	34 ¹ / ₁₆ "	—	58 ¹ / ₁₆ "	—	29 ¹ / ₃₂ "	—
501R	34 ¹ / ₁₆ "	—	58 ¹ / ₁₆ "	—	29 ¹ / ₃₂ "	—
590 (door panels)	15 ¹ / ₁₆ "	20 ³ / ₁₆ "	67 ¹ / ₁₆ "	—	—	—
590 (trim panels)	frz.	2 ³ / ₁₆ "	—	—	—	—
	ref.	—	6 ³ / ₁₆ " (upper) 6 ³ / ₁₆ " (lower)	—	—	—
506	17"	—	13 ³ / ₁₆ "	11 ¹ / ₁₆ "	—	8 ¹ / ₁₆ "
801 (both)	16 ³ / ₁₆ "	—	22 ³ / ₁₆ "	—	11 ¹ / ₂ "	—
249R	23 ³ / ₁₆ "	—	30"	—	15"	—
249RP	23 ³ / ₁₆ "	—	30"	—	15"	—
249FF	23 ³ / ₁₆ "	—	30"	—	15"	—
245	23 ¹ / ₂ "	—	28 ¹ / ₁₆ "	—	—	—

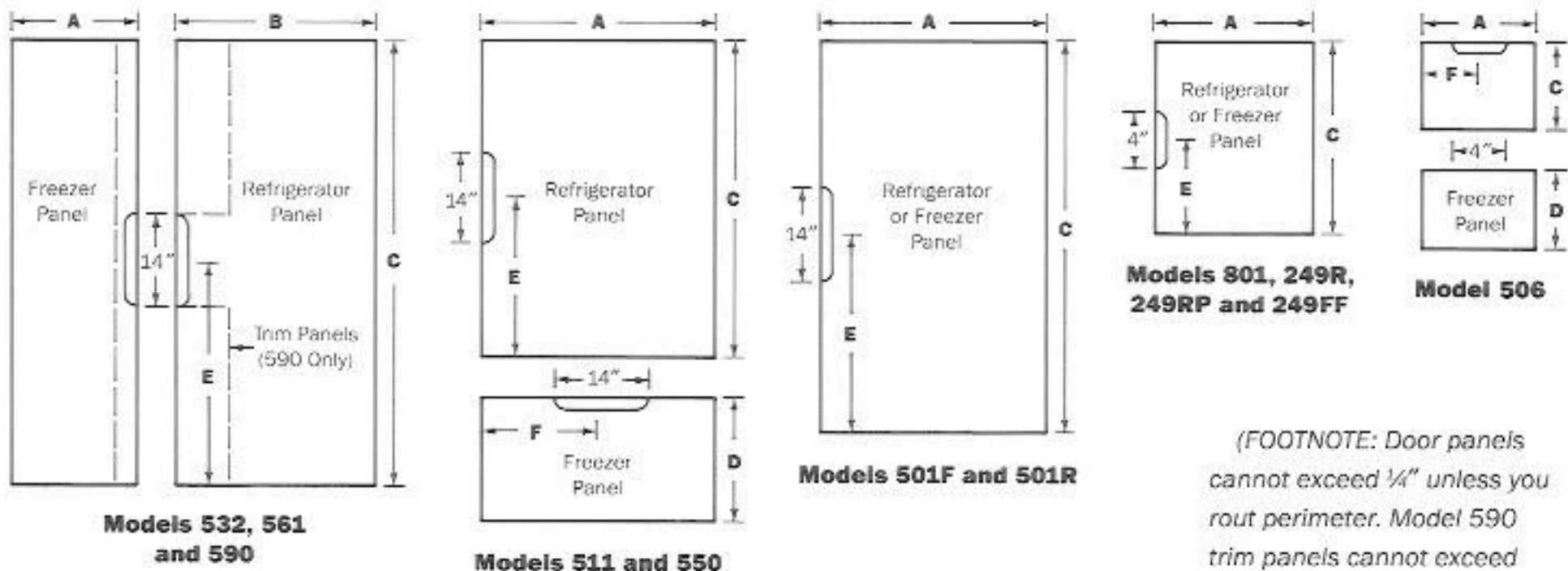

Figure 5

(FOOTNOTE: Model 590 handle profile does not require handle recess when using raised panels.)

(FOOTNOTE: Door panels cannot exceed 1/4" unless you rout perimeter. Model 590 trim panels cannot exceed .050" thickness.)