



**ICEMAKER SYSTEM INFORMATION**

The model 700TFI-3 utilizes a Modular ® icemaker, while the models 700TCI-3 and 736TCI-3 utilize either a MidSouth ® Icemaker, or Japan-Servo ® Icemaker.

**This section is divided in two parts**

<b>ICEMAKER MODEL</b>	<b>PAGES</b>
Modular Icemaker Information (Model 700TFI-3 Only) .....	6-3 through 6-5
MidSouth and Japan-Servo Icemaker information (Models 700TCI-3 and 736TCI Only) .....	6-6 through 6-13

**Additional Icemaker System Information**

- *The ICE ON/OFF key at the control panel activates the icemaker system. If "ICE" is not displayed on the LCD, the icemaker system is OFF.*
- *To allow ice to freeze fully and reduce effects of low water pressure, the electronic control system disables the icemaker system for 45 minutes after each ice harvest. To bypass the 45 minute dwell, press the ICE key to switch the ice making system OFF, then press the ICE key again to cycle the ice making system back ON.*
- *The ice bucket activates a switch when in place. If the ice bucket is not in proper position, ice production will stop.*
- *The icemaker shut-off arm must be in the "down / on" position for the icemaker to operate.*
- *The icemaker relay on the control board also controls the fill tube heater and water valve.*

**MODULAR ICEMAKER OPERATION (700TFI-3 ONLY)**

When the icemaker thermostat has sensed temperatures of 17°F, the thermostat closes. At this time, the current now has a path through the thermostat to the motor. The motor is linked with the drive gear. From the module, there are copper contacts that ride on copper strips on the backside of the drive gear. (See Figure 6-1) As the drive gear rotates, these contacts from the module will make or break a circuit (track) to the copper strips to generate the icemaker cycle.

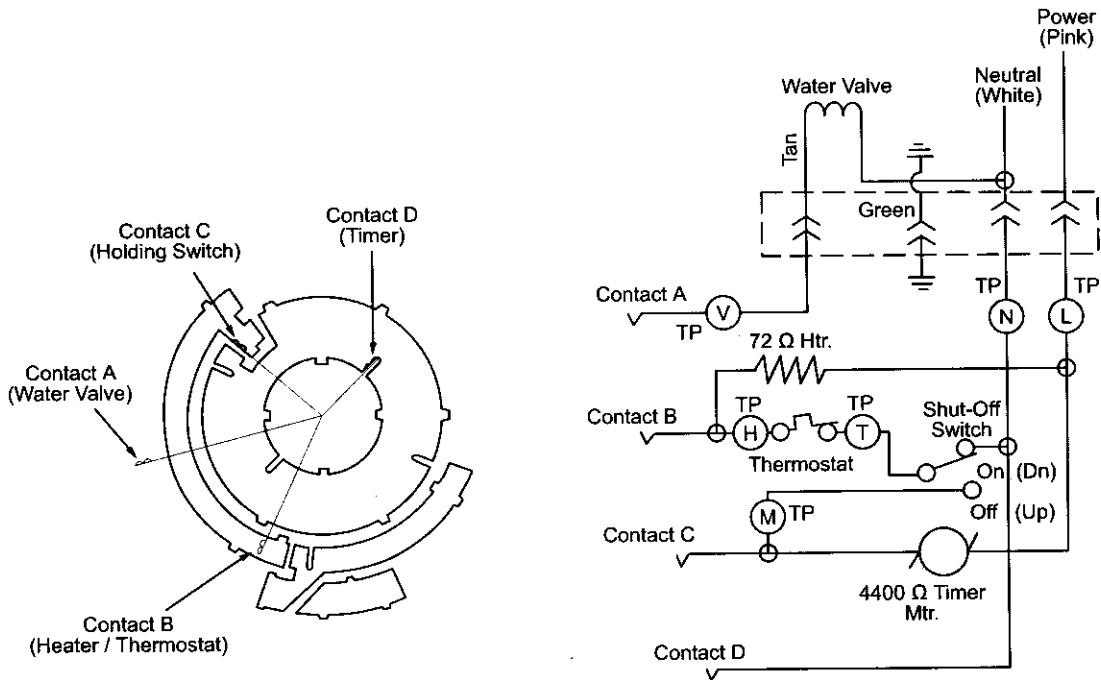

**Figure 6-1. Modular Icemaker Electrical Schematic**

**What Happens During Modular Icemaker Ejector Blade Rotation (700TFI-3 ONLY)**

Figure 6-2 represents a view of the ejector blade from the front (or module side) of the icemaker. This diagram indicates what happens during the rotation of the ejector blade and will assist the Service Technician in diagnosing icemaker problems.

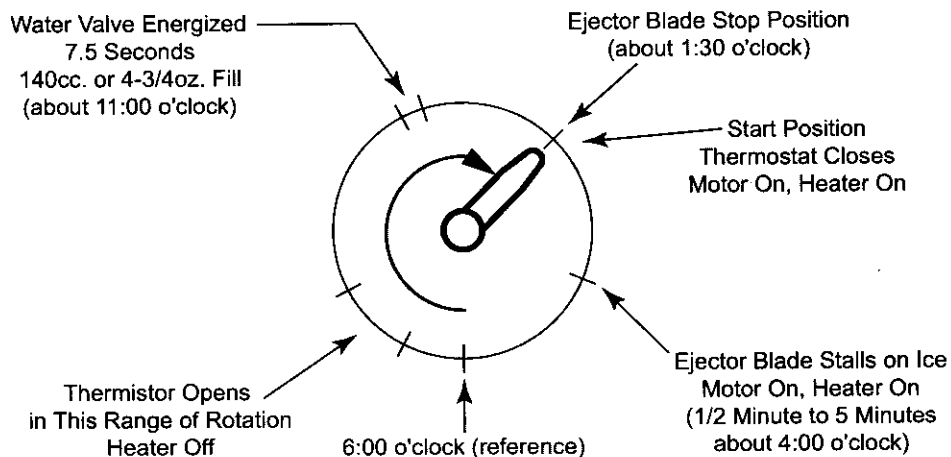

**Figure 6-2. Ejector Blade Rotation Diagram**

**MODULAR ICEMAKER TEST PROCEDURES (700TFI-3 ONLY)**

Perform the following tests if the icemaker is thought to be defective. See Figure 6-3 for icemaker test port locations. Test 1 through 5 are performed with AC power supplied to the icemaker, so read the "WARNING" below and the "additional Ice Production Notes" on the previous page before proceeding.

**⚠ WARNING**

**ELECTRIC SHOCK HAZARD! TESTS 1 THROUGH 5 BELOW ARE PERFORMED WITH POWER SUPPLIED TO THE ICEMAKER. CARE MUST BE TAKEN WHEN PERFORMING THESE TESTS TO AVOID SEVERE PERSONAL INJURY OR DEATH.**

**Voltage Tests**

1. Check for 115 Volts AC between ports "L" and "N". Make sure test probes go into test ports 1/2".
2. Strip 1/2" of insulation from each end of a 3" piece of insulated 14 gauge wire to create a jumper/test wire. Insert the stripped ends of this jumper/test wire into ports "T" and "H" to bypass the thermostat.

**NOTE:** Do not place the jumper/test wire between any other ports as this will damage the icemaker.

If the motor doesn't run, replace the module/motor assembly.

3. Leave the jumper/test wire in until the ejector blades rotate to approximately 8:00 o'clock. The mold heater should heat up. If not, see test 5 below.
4. Remove the jumper/test wire when the ejector blades reach the 8:00 o'clock position. The water valve should energize for 7.5 seconds when the ejector blades rotate to approximately 11:00 o'clock. If not, repeat test 2 through 4 and check for 115V AC to solenoid when ejector blades rotate to approximately 11:00 o'clock. If no voltage, check electrical connections.

**Continuity Tests and Thermostat Inspection**

5. With icemaker removed from the unit, check the resistance of the mold heater between ports "L" and "H." Reading should be between 62 - 82 Ohms. Replace mold/heater assembly if outside this range.
6. With the module/motor separated from the mold/heater assembly, check the resistance of the motor between ports "L" and "M." Reading should be between 3390 - 4410 Ohms. Replace module/motor assembly if outside this range.
7. If icemaker passes tests 1 through 6, check for adequate supply of Thermal-Mastic on icemaker thermostat. If little or no Thermal-Mastic, apply Thermal-Mastic to thermostat. If adequate supply is present, replace thermostat.
8. See General Troubleshooting Guide if icemaker passes tests 1 through 7.

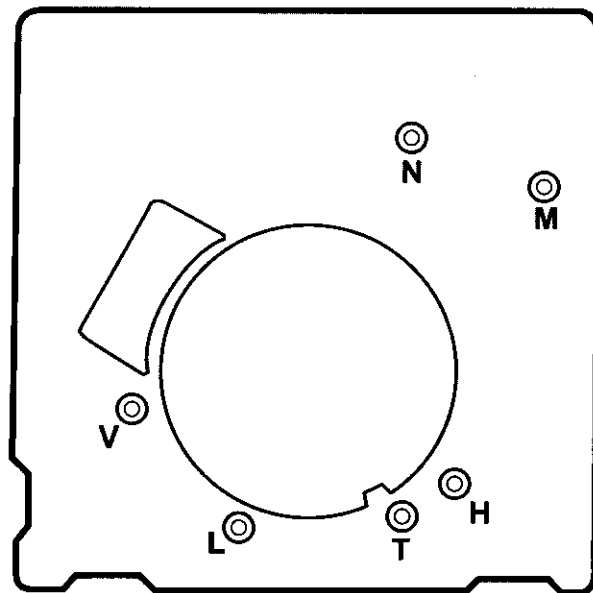

**TEST PORTS**

- H - T = Thermostat
- L - H = Heater
- L - M = Motor
- L - N = AC Line Voltage
- V - N = Valve

**Figure 6-3. Icemaker Test Ports**

**NOTE:** Never attempt to turn the icemaker ejector blades by hand. Doing so will damage the icemaker

### MODULAR ICEMAKER WATER FILL ADJUSTMENT (700TFI-3 ONLY)

The water valve should energize for approximately 7.5 seconds. This should supply 140cc. of water to the icemaker, or approximately 4.75oz. If this is not the case, the fill amount can be adjusted with the water fill adjustment screw. (See Figure 6-4)

To increase the fill amount, turn the water fill adjustment screw counterclockwise. To decrease the fill amount, turn the water fill adjustment screw clockwise. A 360° turn will affect the fill by 40cc. A 180° turn will effect the fill by 20cc.

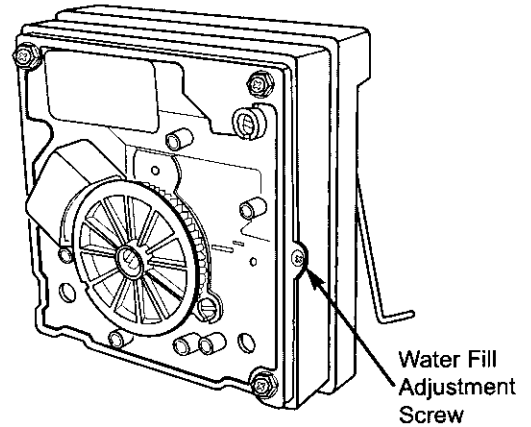

Figure 6-4. Water Fill Adjustment

### MODULAR ICEMAKER DISASSEMBLY (700TFI-3 ONLY)

#### Module/Motor Assembly Removal

To remove the module/motor assembly, first remove the cover and the shut-off arm. Then, extract the module/motor assembly mounting screws and pull the module from the support. (See Figure 6-5)

#### Mold/Heater Assembly Removal

To remove the mold/heater assembly, first remove the cover and the shut-off arm. Insert a Phillips head screwdriver into the access holes and extract the screws. Then, pull the mold/heater assembly from the support. (See Figure 6-5)

#### Ejector Blades and/or Ice Stripper Removal

To remove the ejector blades and/or ice stripper, first remove the cover and the shut-off arm and disconnect the mold/heater assembly from the support. (See Figure 6-5) Then, pull the ejector blades and/or ice stripper from the mold.

#### Icemaker Thermostat Removal

To remove the icemaker thermostat, first remove the cover and the shut-off arm and disconnect the mold/heater assembly from the support. (See Figure 6-5) Then, use a needle-nose pliers to grasp one of the retaining clips and pull out. (See Figure 6-6)

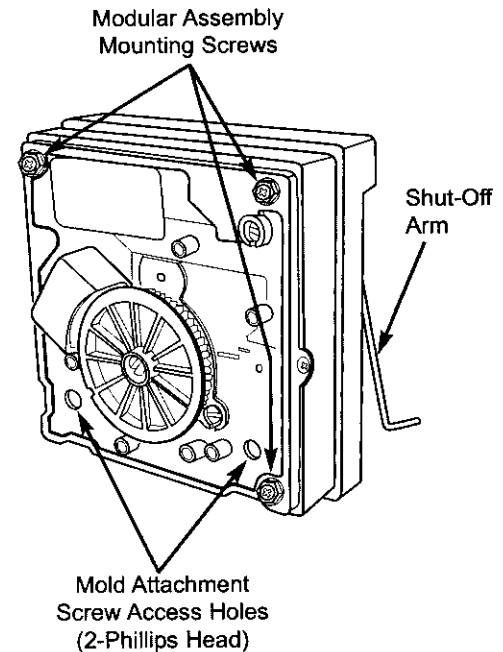

Figure 6-5. Icemaker Component Removal

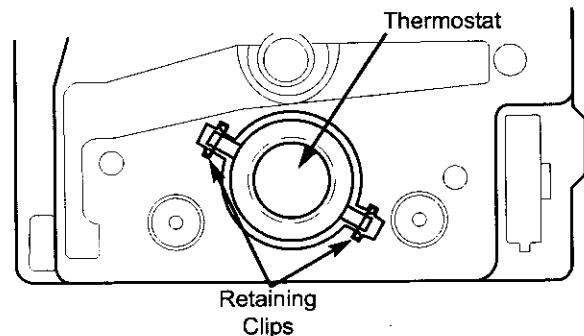

Figure 6-6. Thermostat Retaining Clips



**MIDSOUTH AND JAPAN-SERVO ICEMAKER COMPONENTS  
(700TCI-3 AND 736TCI-3 ONLY)**

Following are descriptions that explain the function of each icemaker component. The components are diagrammed in Figure 6-7, below.

**Support** - The support is the housing around the electrical components and wire connections. The support is attached to the ice mold.

**Mounting Plate** - The drive motor, holding switch, water valve solenoid switch, timing gear, timing cam and water fill adjusting screw are attached to the metal mounting plate. The mounting plate is then attached to the support.

**Drive Motor** - 115 volts AC supplied to the drive motor causes the motor to operate. The motor has a single output shaft with a small gear. The motor gear drives/spins the timing gear.

**Timing Gear** - The timing gear is driven/spun by the drive motor gear and is attached to the timing cam.

**Timing Cam** - The timing cam is attached to the timing gear and the ice ejector is inserted into the center of the timing cam. As the timing cam rotates, high and low spots on the cam operate the water valve solenoid switch and the holding switch. The timing cam also moves the lever arm side to side and rotates the ice ejector.

**Ice Mold** - The ice mold is where the eight crescent shaped ice cubes are formed.

**Mold Heater** - The mold heater uses 165 watts to thaw the ice free from the mold.

**Ice Ejector** - The drive end of the ice ejector is "D" shaped to fit into the "D" shaped hole in the timing cam. It has eight blades which rotate and sweep the ice from the mold cavities during the ejection phase of the cycle.

**Ice Stripper** - The stripper is attached to the dumping side of the mold, serving as a decorative side cover and it also prevents ice from falling back into the mold.

**Bearing / Inlet** - The bearing / inlet is attached to the ice mold, opposite the support. Water enters the bearing / inlet and is directed to the ice mold. The bearing/inlet also supports the ice ejector at the end opposite the timing cam.

**Thermostat** - The thermostat is a single-pole, single-throw, bi-metal switch. At 15°F (-9°C) ± 3° it closes, starting the ice ejection phase.

**Thermal-Mastic** - A substance similar in appearance to grease that is applied between the thermostat and the ice mold. Its purpose is to increase thermal conductivity between the mold and the thermostat.

**Lever Arm and Shut-off Arm** - The lever arm is moved side to side by two revolutions of the timing cam. As it moves, it raises and lowers the shut-off arm and operates the shut-off switch to control the quantity of ice production. If the shut-off arm comes to rest on top of the ice in the storage bin during either revolution, the shut-off switch will remain open, stopping ice production at the end of that revolution.

**Water Valve Solenoid Switch** - A single-pole, double-throw type switch that allows electricity to the water valve solenoid, opening the valve, during the fill cycle.

**Holding Switch** - A single-pole, double-throw type switch that assures completion of a revolution once the icemaker has been energized.

**Shut-off Switch** - A single-pole, double-throw type switch that stops ice production when the ice bin is full.

**TCO (Thermal Cut Out)** - The TCO is thermal protection device in the wire harness that would open in the event of mechanical failure, thus protecting against over heating. (The TCO is not shown in diagram.)

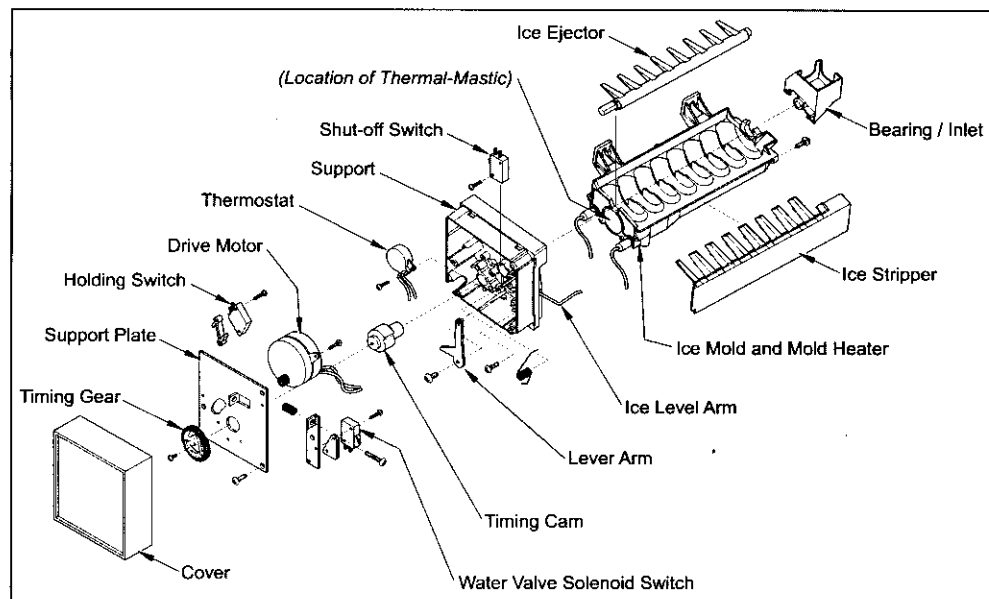

**Figure 6-7. Diagram of Icemaker Components**

### MIDSOUTH AND JAPAN-SERVO ICEMAKER OPERATION (700TCI-3 AND 736TCI-3 ONLY)

The following series of electrical schematics illustrate a typical icemaker cycle of operation. Below each schematic is a diagram indicating the approximate location of the ice ejector and ice level arm during the phase the schematic indicates.

#### Freeze Phase of Ice Making Cycle (See Figure 6-8)

- The ice mold is filled with water.
- The thermostat is open.
- No icemaker components are energized.

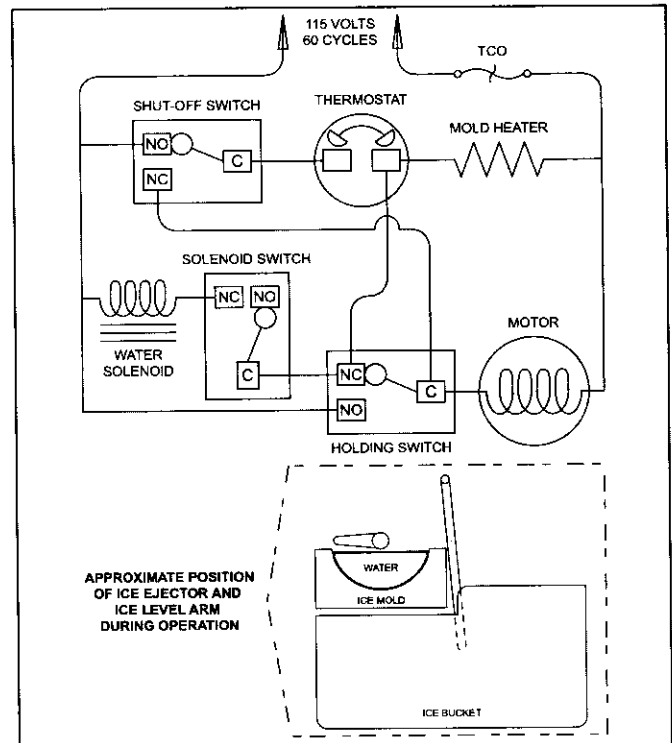

Figure 6-8. The Freeze Phase

#### Start of the First Revolution (See Figure 6-9)

- The water in the ice mold has turned to ice.
- At  $15^{\circ}\text{F} (-9^{\circ}\text{C}) \pm 3^{\circ}$  the thermostat closes.
- The mold heater is energized through the thermostat.
- The drive motor is started through the thermostat and "normally closed" terminal of the holding switch.
- The ice ejector begins to turn and the shut-off arm begins to rise.

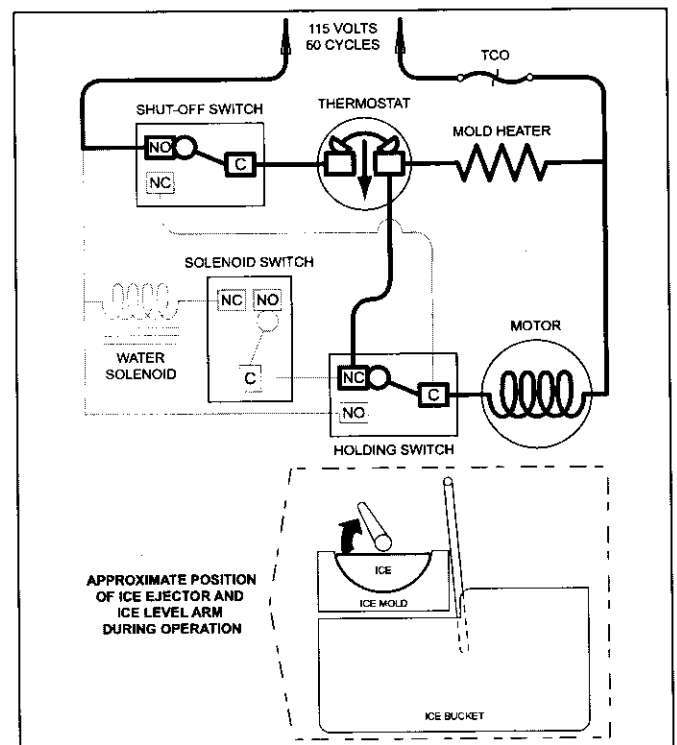
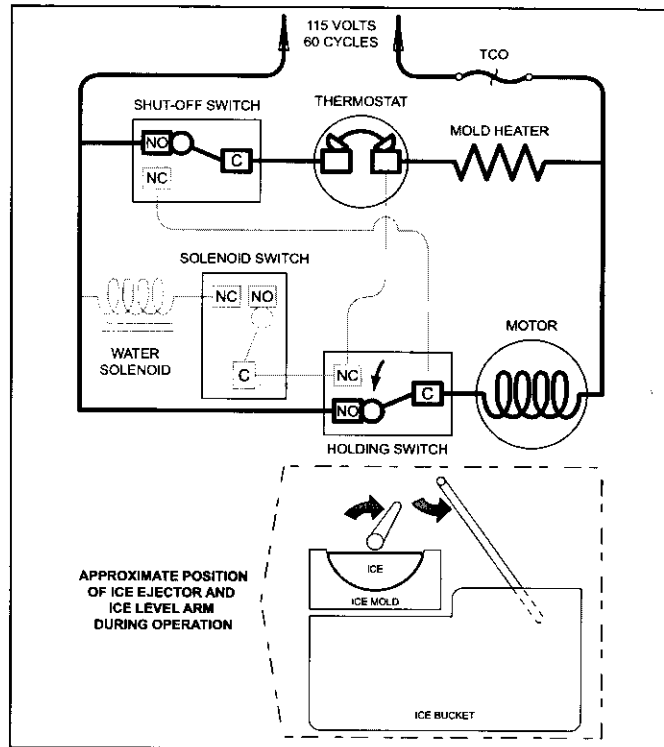

Figure 6-9. Start of First Revolution

**First Revolution Continued (See Figure 6-10)**

- The holding switch is tripped by the timing cam to “normally open” thus holding power to the motor.
- The mold heater remains energized through the thermostat.
- The shut-off arm begins to rise.



**Figure 6-10. First Revolution Continued**

**First Revolution Continued (See Figure 6-11)**

- The ice ejector reach the ice in the mold.
- The ice releases from the mold as the ejector blades begin to rotate the cubes out.
- The drive motor remains energized through the holding switch.
- The mold heater remains energized through the thermostat.
- As the shut-off arm rises, the shut off switch is tripped to “normally closed”, and then the shut-off arm begins to lower.

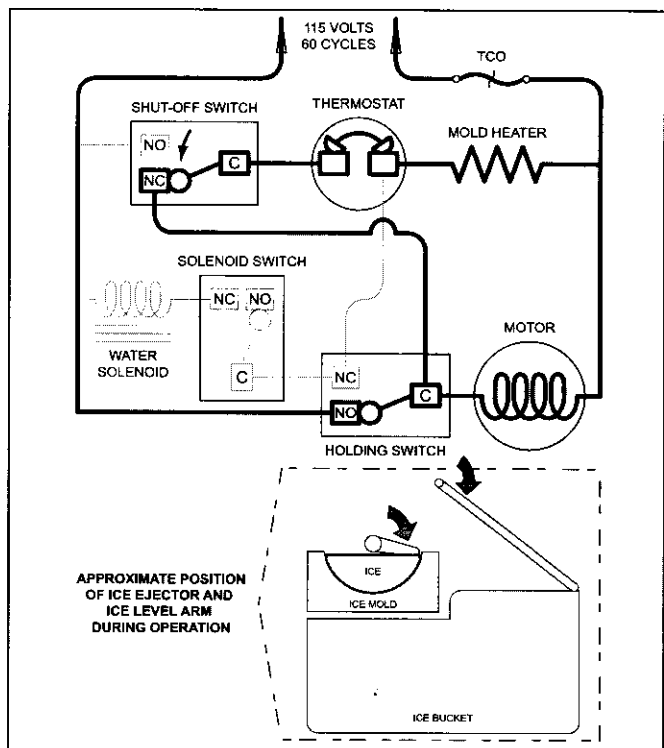

**Figure 6-11. First Revolution Continued**

**First Revolution Continued (See Figure 6-12)**

- The ice has released from the mold.
- The motor remains energized through the holding switch.
- The shut-off arm is lowered and the shut off switch is tripped to “normally open”.
- The water valve solenoid switch is tripped by the timing cam, but the solenoid is not energized because the thermostat is still closed and energizing the mold heater. (Electric current follows the path of least resistance.)

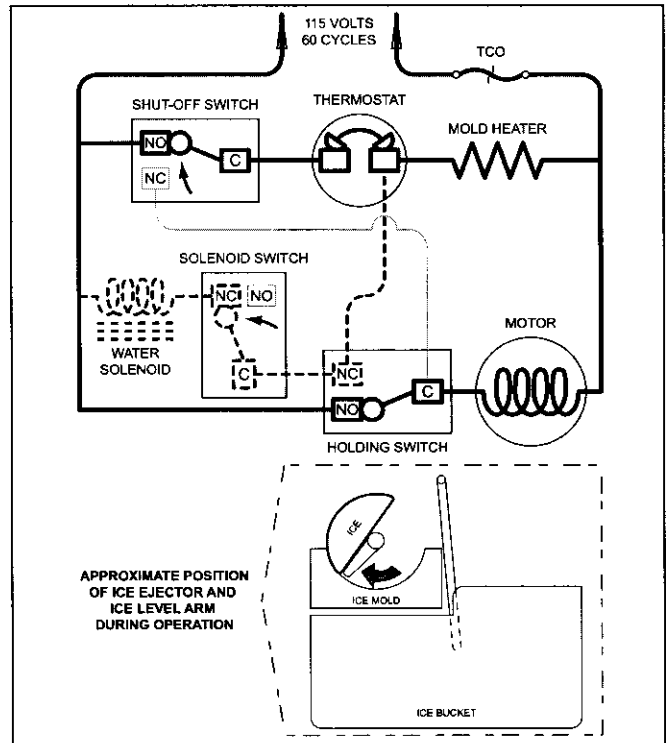

**Figure 6-12. First Revolution Continued**

**End of First Revolution (See Figure 6-13)**

- The water valve solenoid switch is tripped by the timing cam back to “normally open.”
- The timing cam trips the holding switch to “normally close,” which ends the first revolution, but the thermostat is still closed, so the motor is again started.
- The mold heater remains energized through the thermostat.

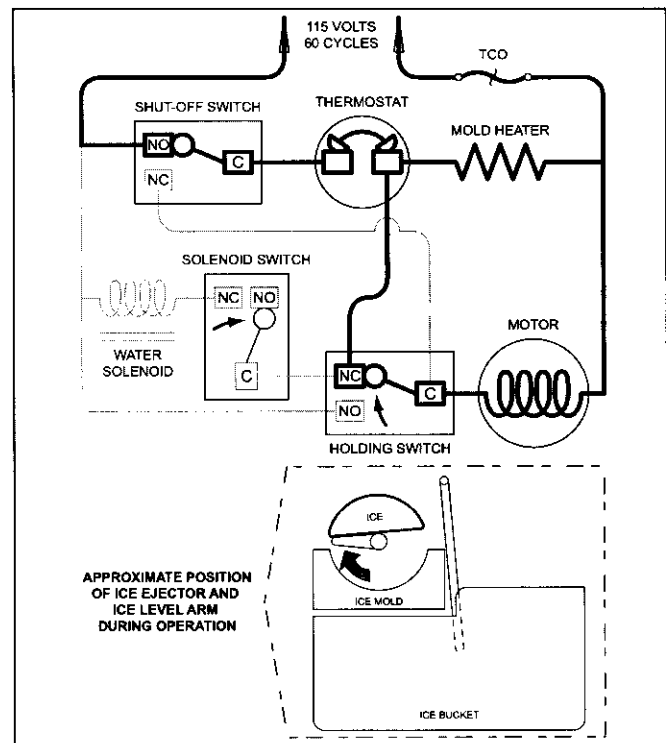

**Figure 6-13. End of First Revolution**

**Start of Second Revolution (See Figure 6-14)**

- The water valve solenoid switch is tripped by the timing cam back to “normally open.”
- The timing cam trips the holding switch to “normally close,” which ends the first revolution, but the thermostat is still closed, so the motor is again started.
- The mold heater remains energized through the thermostat.

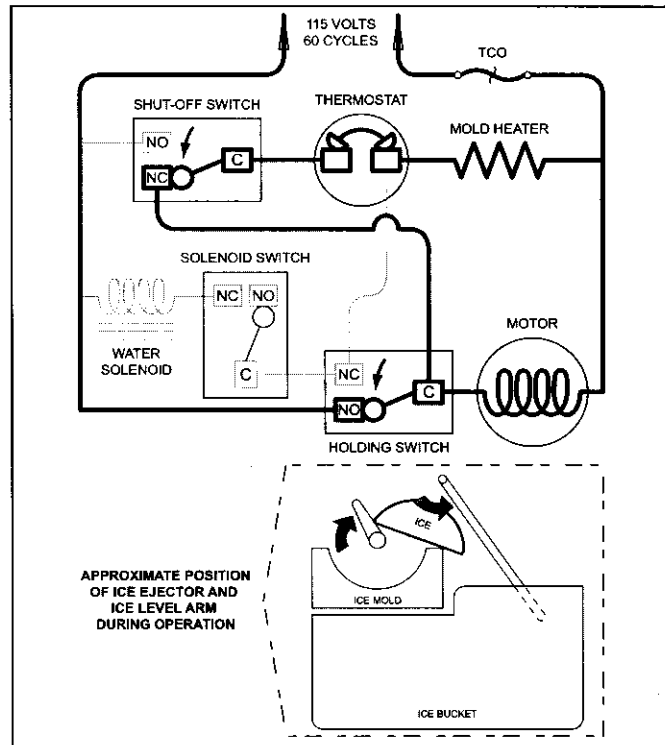

Figure 6-14. Start of Second Revolution

**Second Revolution Continued (See Figure 6-15)**

- The mold heater has warmed the thermostat, so the thermostat opens, and the mold heater is de-energized.
- If the shut-off arm comes to rest on top of the ice in the storage bin (as illustrated), so the shut-off switch will remain in the “normally closed” position.
- The motor remains energized through the holding switch.

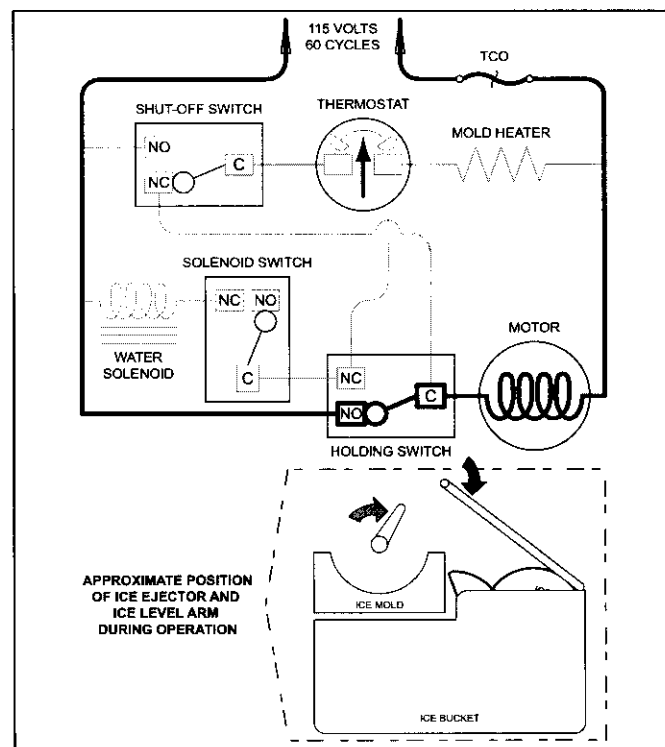
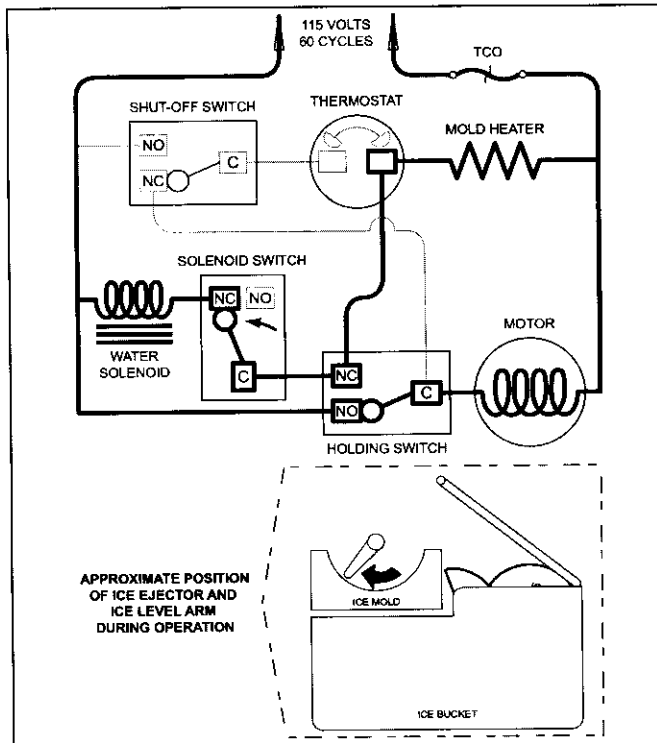

Figure 6-15. Second Revolution Continued

**Second Revolution Continued (See Figure 6-16)**

- The water valve solenoid switch is tripped by the timing cam. This time the solenoid is energized because the thermostat is open. The water solenoid is open for approximately seven seconds, filling the ice mold with water.
- the mold heater is energized through the solenoid switch and holding switch.

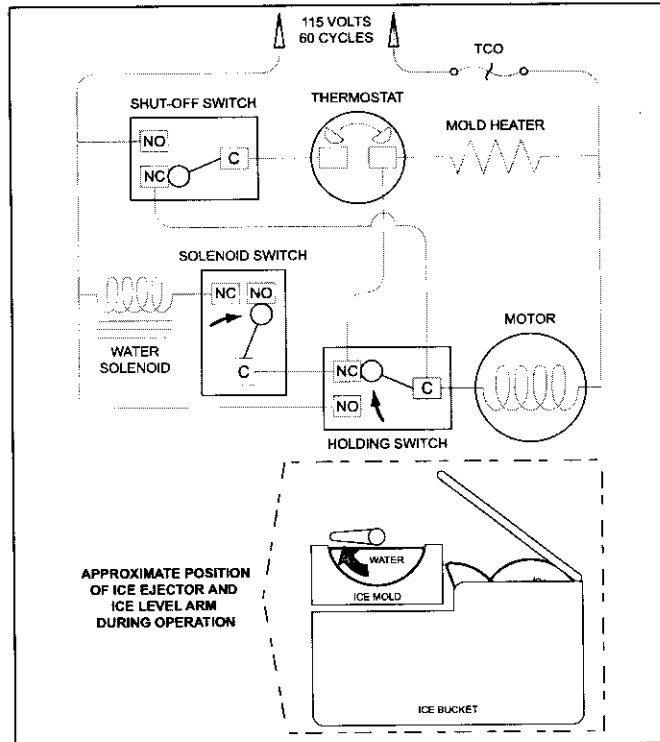

**Figure 6-16. Second Revolution Continued**

**End of Ice making Cycle (See Figure 6-17)**

- The water valve solenoid switch is tripped by the timing cam back to “normally open” ending the water fill.
- The timing cam trips the holding switch to “normally close,” which ends the second revolution.
- The thermostat is still open, so it does not start the drive motor.
- If the shut-off arm has come to rest on top of the ice in the storage bin (as illustrated), the shut-off switch remains in the “normally closed” position. This interrupts power from reaching the thermostat, until sufficient ice has been removed from the storage bin allowing the shut-off arm to lower.

**NOTE:** To allow ice to freeze fully and reduce effects of low water pressure, the electronic control system disables the icemaker system for 45 minutes after each ice harvest.



**Figure 6-17. End of Ice Making Cycle**

## MANUALLY STOPPING ICE PRODUCTION

Ice production can be manually stopped three ways:

1. Press the ICE ON/OFF key on the control panel so that "ICE" is not displayed on the LCD.
2. Remove ice bucket so that icemaker switch behind the ice bucket is not being depressed. Also, make sure no food product is coming in contact with icemaker switch.
3. Position the ice-level/shut-off arm in the up/OFF position (See Figure 6-18).

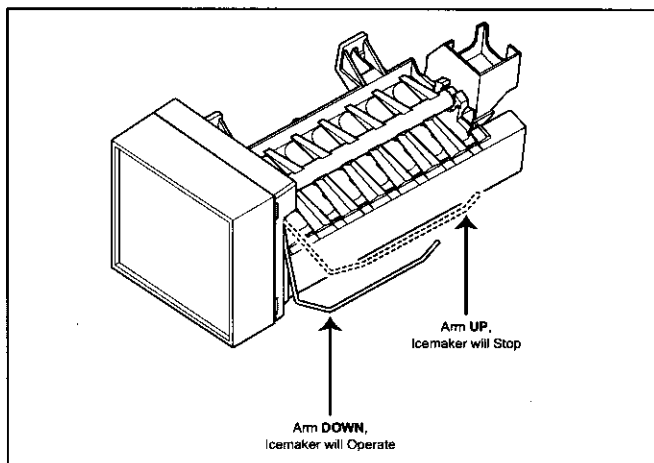

Figure 6-18. Stopping Icemaker

## MANUALLY STARTING THE ICEMAKER

**NOTE:** To allow ice to freeze fully and reduce effects of low water pressure, the electronic control disables the icemaker system for 45 minutes after each ice harvest. To bypass this 45 minute dwell for service purposes, press the the ICE ON/OFF key at the control panel.

### Manual Start Procedure:

1. Pry the icemaker front cover from the support using a flat-blade screwdriver or coin.
2. With a flat-blade screwdriver, turn the drive gear counterclockwise until the holding switch is activated, completing the circuit to the drive motor (this will be about a 1/8 turn). (See Figure 6-19) The icemaker will then complete its cycle automatically.

**NOTE:** If after 1/4 turn the icemaker is not running on its own, it may be in the 45 minute dwell period or there is an electrical or mechanical problem.

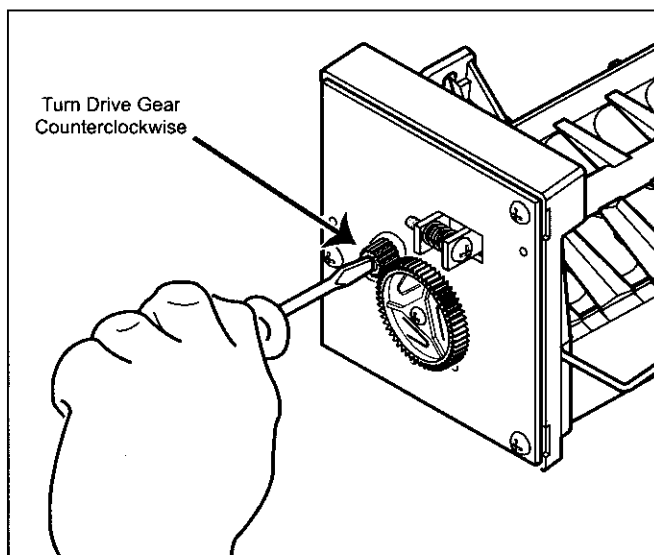

Figure 6-19. Manually Start Icemaker

## ADJUSTING ICEMAKER WATER FILL LEVEL

Proper water fill level for a MidSouth icemaker is 100 - 110 cc's (3.5 - 3.75 oz). If the fill level is checked and needs to be adjusted, turn the water fill adjusting screw clockwise to reduce fill level, or counterclockwise to increase fill level. One full turn of the screw equals 15 cc's. (See Figure 6-20)

**NOTE:** Always check fill level before making any adjustments of the water fill adjusting screw.

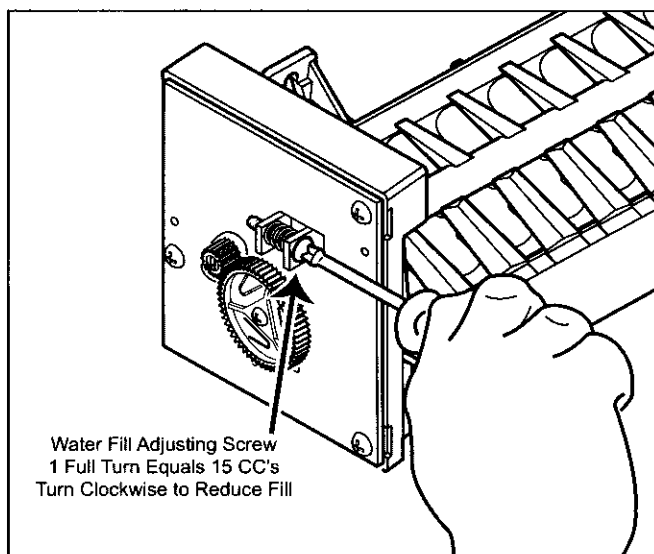

Figure 6-20. Adjust Water Fill Level

## ICEMAKER FAULT TESTING

Bypass 45-minute dwell by pressing ICE ON/OFF key to OFF then ON. Then depress icemaker switch & manually start icemaker by turning driver gear counter-clockwise with screwdriver.

### 1 If icemaker starts & finishes cycle:

(NOTE: If  $>15^{\circ}\text{F}$  ( $-9^{\circ}\text{C}$ ), icemaker will only complete 1 revolution.)

- Visually inspect electrical connections at icemaker & valve. Repair if necessary.
- Check valve operation with test cord, if doesn't open, replace.
- Check thermostat. Open:  $48^{\circ}$  ( $9^{\circ}\text{C}$ )  $\pm 6^{\circ}$ , Close:  $15^{\circ}$  ( $-9^{\circ}\text{C}$ )  $\pm 3^{\circ}$ . Replace icemaker if defective.
- With icemaker in park position, check solenoid switch terminals "C" & "NO" for continuity. With ejector between 8:00 & 10:00 position, check solenoid switch terminals "C" & "NC" for continuity. If no continuity for either terminal check, replace icemaker.

### 2. If icemaker starts but does not finish cycle:

- With icemaker in park position check holding switch terminals "C" & "NC" for continuity. Then with icemaker ejector between 10:00 & 12:00, check holding switch terminals "C" & "NO" for continuity. If no continuity for either terminal check, replace icemaker. (Refer to enclosed wiring diagram)
- With icemaker in park position check shut-off switch terminals "C" & "NO" for continuity. With ejector between 12:00 & 2:00 check shut-off switch terminals "C" & "NC" for continuity. If no continuity for either terminal check, replace icemaker.
- Check mold heater for 75-85 $\Omega$ . If outside range, replace icemaker.

### 3 If icemaker motor does NOT start:

- Lower shutoff arm
- Check motor operation with test cord. If motor doesn't run, replace icemaker.
- Check power to & from icemaker switch. Reconnect or repair connection or replace icemaker as necessary.
- Check for 115V AC from control board. If power is present check & repair connection. If no power, replace control board.

## QUICK REFERENCE

- Water Fill Time - 6.3 $\pm$ 2 seconds
- Fill Tube Heater Ohm - 2850-3890 $\Omega$
- Mold Heater Ohm - 75-85 $\Omega$
- Water Valve Ohm - 160-165 $\Omega$
- Thermostat - Open:  $48^{\circ}$  ( $9^{\circ}\text{C}$ )  $\pm 6^{\circ}$ , Close:  $15^{\circ}$  ( $-9^{\circ}\text{C}$ )  $\pm 3^{\circ}$ .
- Water Pressure Needed - 20-100 psi constant

## Possible Problems

### No / Slow Ice Production

- Ice maker system switched OFF. Switch ice system ON.
- Shut off arm in up/OFF position. Move to ON position.
- Freezer too warm. Check temp's & see troubleshooting guide in service manual.
- Poor airflow over icemaker. Remove obstructions.
- Ice cube jam. Remove ice & check water fill setting.
  - Water fill setting too low ( $< 6.5$  sec's). Adjust setting.
  - Water fill setting too high ( $> 7$  sec's). Adjust setting.
- Water froze in inlet tube. Remove ice from tube. Check for 115VAC from control board; Fill tube heater = 2850-3890 $\Omega$ .
- Water supply not constant 20-100 psi. Instruct customer.
- Water line to unit pinched/kinked. Repair water line.
- Saddle valve not installed correctly to supply line. Reposition.
- Saddle valve not fully open. Open valve fully.
- Icemaker wire/connections loose/broken. Repair wiring.
- Water valve wire/connections loose/broken. Repair wiring.
- Defective water valve. Check valve (160-165 $\Omega$ ), Replace valve.
- Thermostat wire/connections loose/broken. Repair wiring.
- TCO overheat or short. Replace icemaker.
- See Icemaker Fault Testing.

### No Water Fill

- Water supply switched OFF. Switch supply water line ON.
- Water line to unit pinched/kinked. Repair water line.
- Saddle valve not installed correctly to supply line. Reposition.
- Water froze in inlet tube. Remove ice from tube. Check for 115VAC from control board; Fill tube heater = 2850-3890 $\Omega$ .
- Water valve wire/connections loose/broken. Repair wiring.
- Defective water valve. Check valve (160-165 $\Omega$ ), Replace valve.

### Overflows / Ice Block Forms in Bucket / Oversized Cubes

- Icemaker not level. Level icemaker.
- Unit not level. Level unit
- Water supply not constant 20-100 psi. Instruct customer.
- Water fill setting too high ( $> 7$  sec's). Adjust setting.
- Water fill setting too low ( $< 6.5$  sec's). Adjust setting.
- Defective water valve. Check valve (160-165 $\Omega$ ), Replace valve.

### Ice Cubes Hollow or Small

- Icemaker not level. Level icemaker.
- Unit not level. Level unit
- Water supply not constant 20-100 psi. Instruct customer.
- Water fill setting too low ( $< 6.5$  sec's). Adjust setting.
- Too little thermalastic on thermostat. Add thermalastic.
- Defective thermostat (Open:  $48^{\circ}$  ( $9^{\circ}\text{C}$ )  $\pm 6^{\circ}$ , Close:  $15^{\circ}$  ( $-9^{\circ}\text{C}$ )  $\pm 3^{\circ}$ ). Replace icemaker if defective.

### Too much Ice

- Shut off arm/linkage bent/broken. Repair or replace arm/linkage.
- If ejector blades rotate with arm in up/OFF position - Icemaker faulty. Replace icemaker.